

All-rounder for timber construction.

Our multifunction bridges

WALLTEQ M-300

WALLTEQ M-300 insuFill

WALLTEQ M-500





WALLTEQ multifunction bridges

Versatile, precise and fast

These CNC-controlled machines allow you to carry out all work on the sheathing of wooden frame elements in a fully automatic process – including, for example, the fixing, formatting and production of all openings. Regardless of whether you are working with wall, roof, ceiling or gable elements, these machines can be used in all areas. Both small and large quantities can be produced efficiently and with high precision.

YOUR SOLUTION

[MORE INFORMATION AVAILABLE AT HOMAG.COM/WEINMANN](https://www.homag.com/weinmann)



Product brochure

CONTENTS

- 06 Standard features and options
- 08 WALLTEQ M-300 and options
- 10 WALLTEQ M-500
- 14 WALLTEQ M-500 – Options
- 16 WALLTEQ M-500 – Special areas of application
- 17 WALLTEQ M-300/M-500 insuFill
- 18 Machine layout and technical data
- 20 Configuration options
- 22 Software
- 25 Apps
- 26 LIFE CYCLE SERVICES

Flexibility in wood frame construction

The multifunction bridges are versatile and can be expanded on an individual basis. Depending on the performance and product range required, different versions are available to suit your requirements.

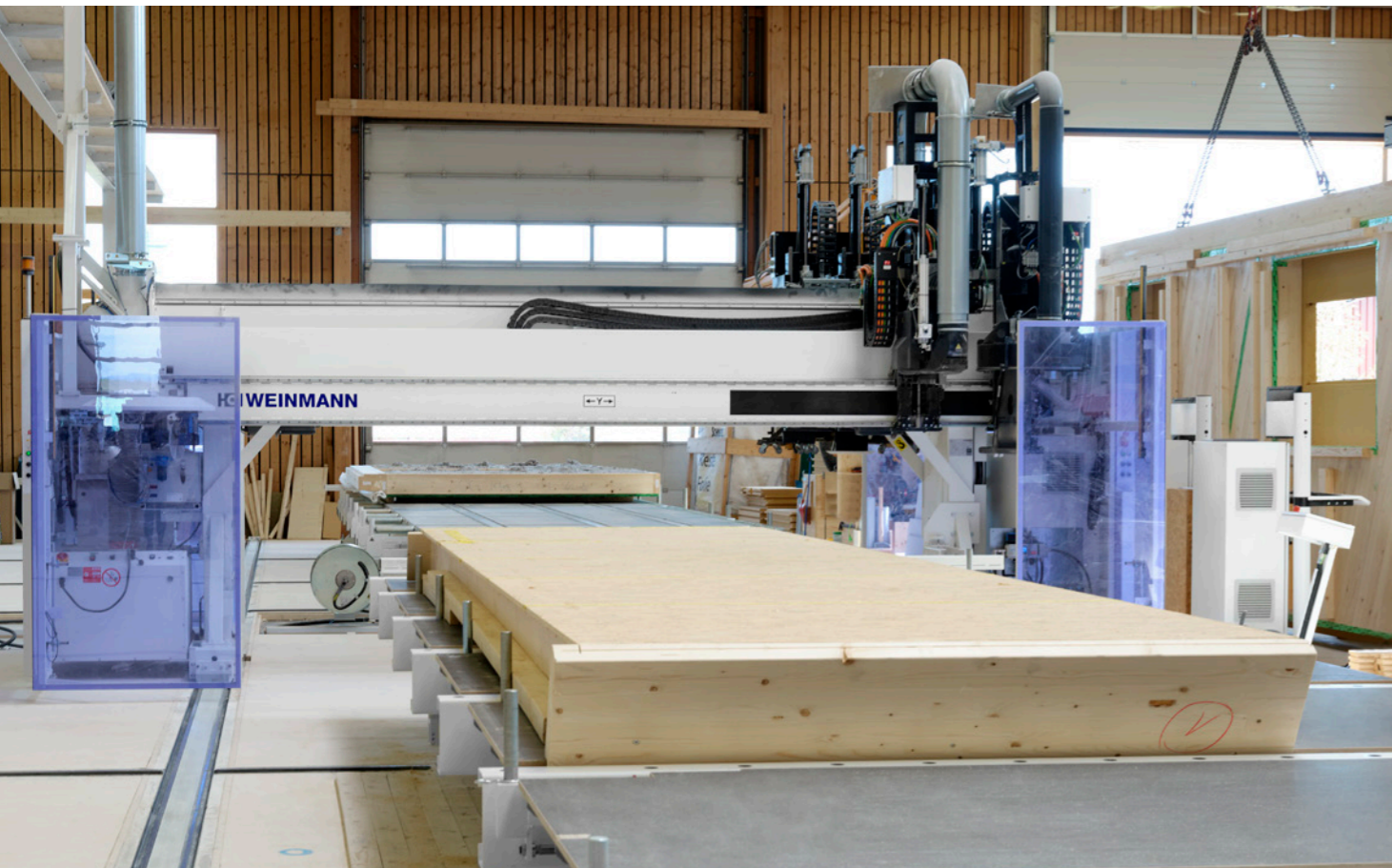

Multifunctional

- Process a wide variety of materials without setup times
- Equipped for the future: The modular design makes it possible to adapt to changing market requirements at any time
- Depending on the design, the machines can be configured according to the customer's individual needs

Proven technology

- CNC controller for fully automatic processing
- Interpolating processing
- Durable design
- Low maintenance thanks to the central lubrication system and toothed belt drive

Powerful complete package

- Optimum working ergonomics and work safety
- Fully automatic data transfer from CAD
- Increased efficiency thanks to structured production processes

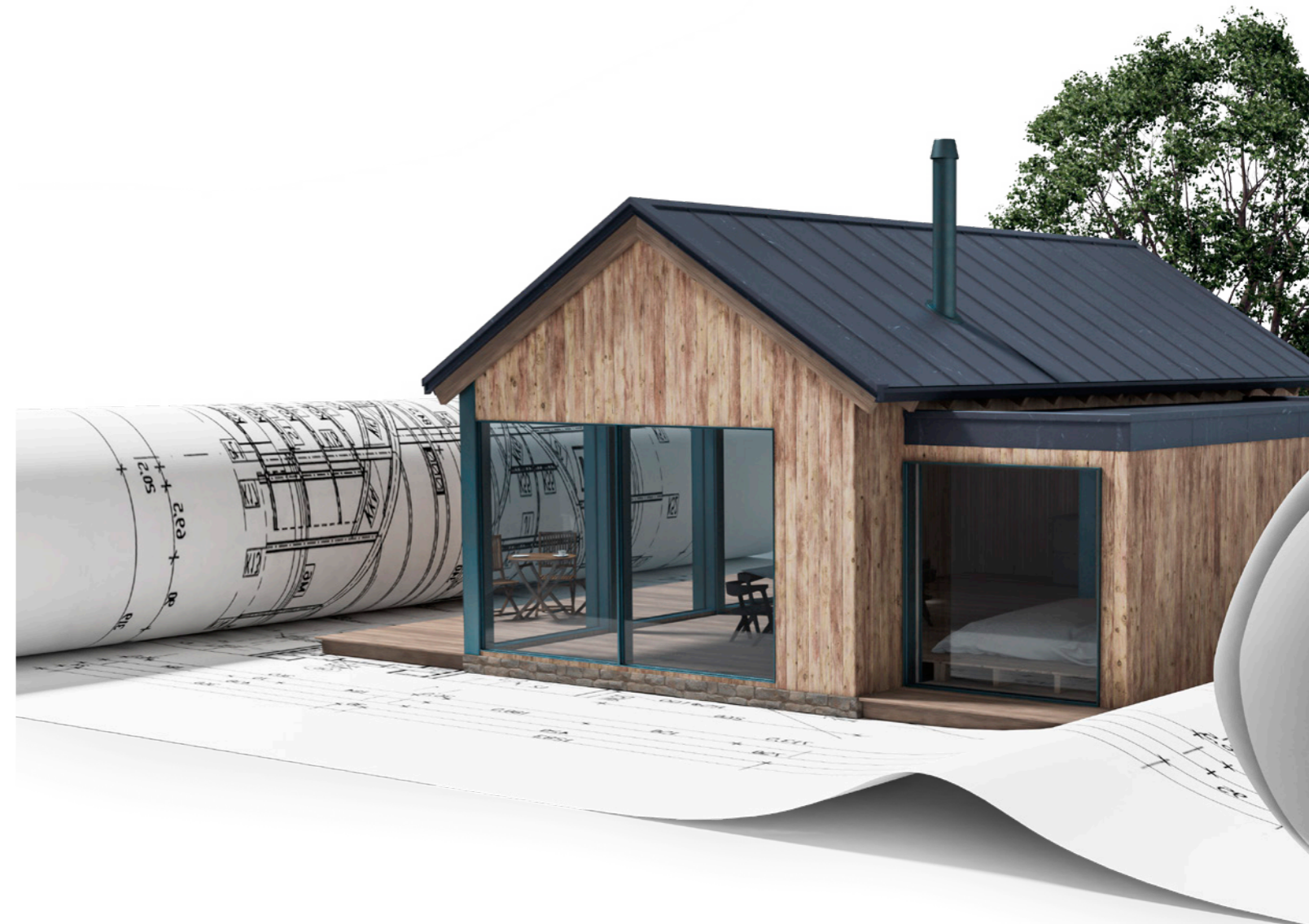

	WALLTEQ M-300	WALLTEQ M-500
	Profitable production of small quantities	Individually configurable
Fastening	Stapling, nailing	Stapling, nailing, screwing
Processing	Trimming, sawing, drilling	Trimming, drilling, sawing
Labeling	Marking	Marking, labeling
Tool changer	Pick-up	12-slot
Fastener chucks	2	Customized

Investment in the future

This machine lets you process a wide variety of elements and materials in a fully automatic process, putting you in the optimum position for producing batch size 1 and for meeting future requirements. Even with the standard features alone, the machines in the WALLTEQ series are equipped with a range of helpful details.



Your step into digitization

- Fully automatic data transfer from all common CAD programs for timber construction
- Easy to operate with intuitive powerTouch user interface
- tapio-ready: all the processes in the value chain combined into a single digital platform
- Continuous data flow from data generation to the finished product (part of the BIM process chain)



Modern production technology

- Extensive processing capabilities thanks to versatile tool change technology
- CNC technology for consistently high accuracy
- Reduced maintenance effort thanks to central lubrication

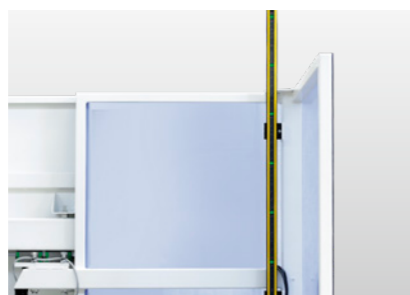

The highest safety standards

- Eight light barriers and four bumpers
- Protected working area, both on the assembly table and on the side of the assembly table



Individual production concepts

- Can be combined with different table concepts; several tables can also be approached
- Can be integrated into a production line at any time

Features to suit your needs

These options can be integrated into any multifunction bridge. You can configure the machine according to your needs and find your solution.



Central extraction system

- Minimize the amount of dust
- Optional: separation of different materials is possible



Modules for the power supply and switch cabinet

- Uninterrupted power supply to safeguard the control computer
- Switch cabinet heating
- Switch cabinet cooling



Activation with remote control

- Start the machine from various positions
- Shorter walking distances and optimal work flow



fastenerSwitch: quick-change system for fastening units

- Fully automatic replacement of various fastening units
- High flexibility: The system provides up to four different fastening units
- Minimized idle times and increased efficiency



Piggyback suction device

- Compact, cost-effective suction unit
- Primarily suited to wood dust
- Automatic filter cleaning with the air jet system

WALLTEQ M-300 multifunction bridge

Multifunctional

The WALLTEQ M-300 offers the ideal entry-level solution for CNC-controlled manufacturing in the field of home building. Wall, ceiling and roof elements can be manufactured quickly and easily, all at an outstanding price-performance ratio.

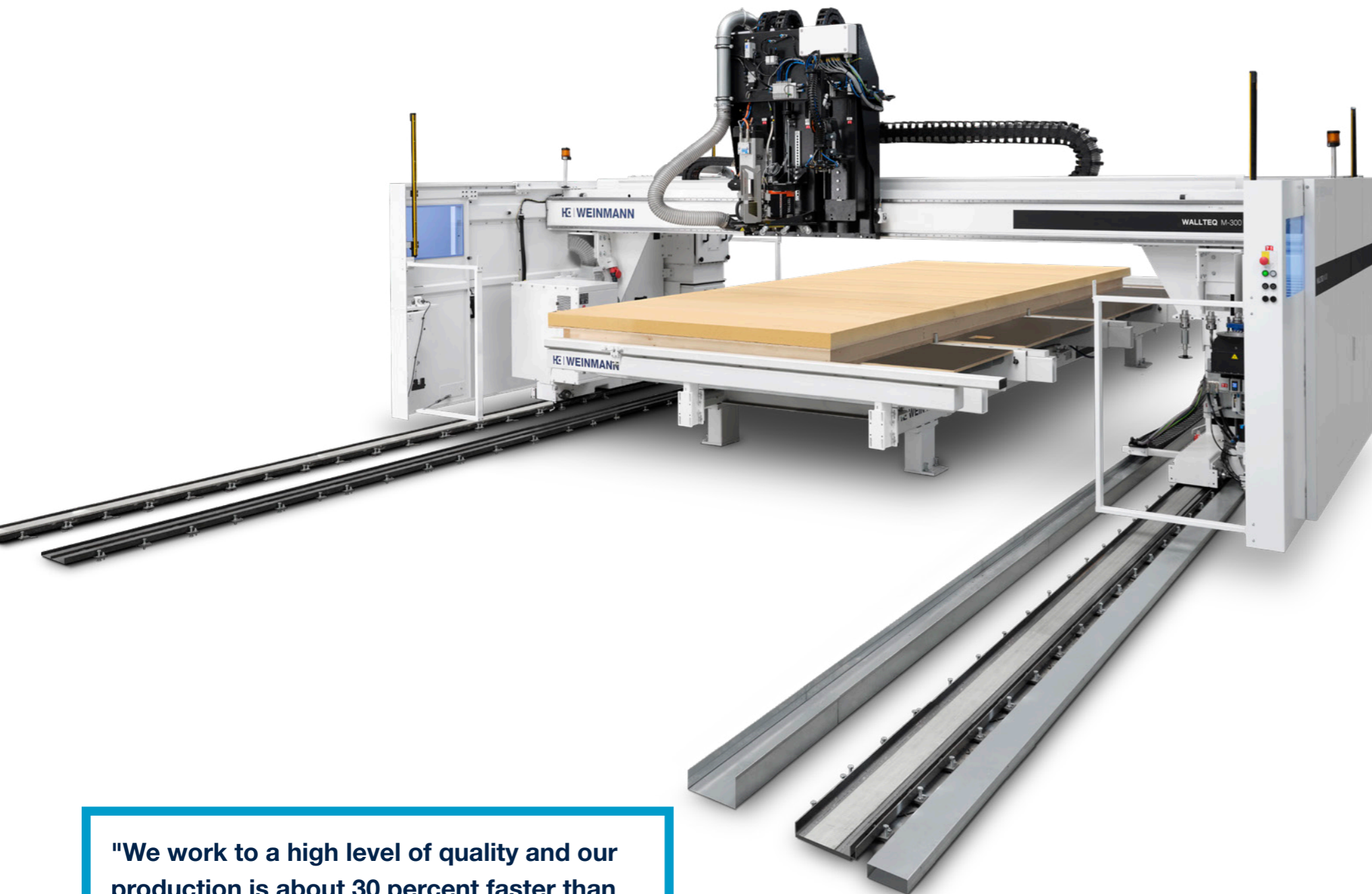

"We work to a high level of quality and our production is about 30 percent faster than manual production, even with the same number of employees."

Christoph Bächle, Abbundzentrum St. Johann



Compact deduster

As dust is usually a nuisance, when developing this function we focused on making it snappy. The compact deduster really gets going, especially when trimming.

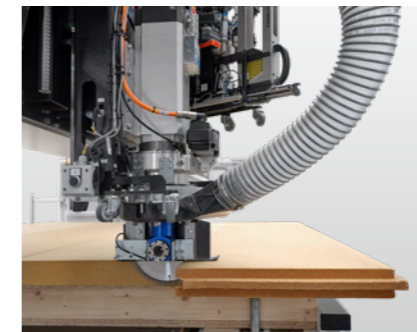

Sawing tool with HSK chuck

In addition to the flexibility of the HSK chuck and the precision of the cut, the cleanliness of the work thanks to the new increased suction power of 2.2 kW is a real winner.



Fully automatic CNC processing

With the sawing unit, tasks that otherwise could only be completed manually on the construction site can be completed precisely and much faster.

- Up to 80 mm cut depth
- Saw protection with integrated suction technology

HIGHLIGHTS:

- Entry-level solution with very low acquisition costs
- Flexible manufacturing of various elements for production in batch size 1
- Fully automatic data transfer

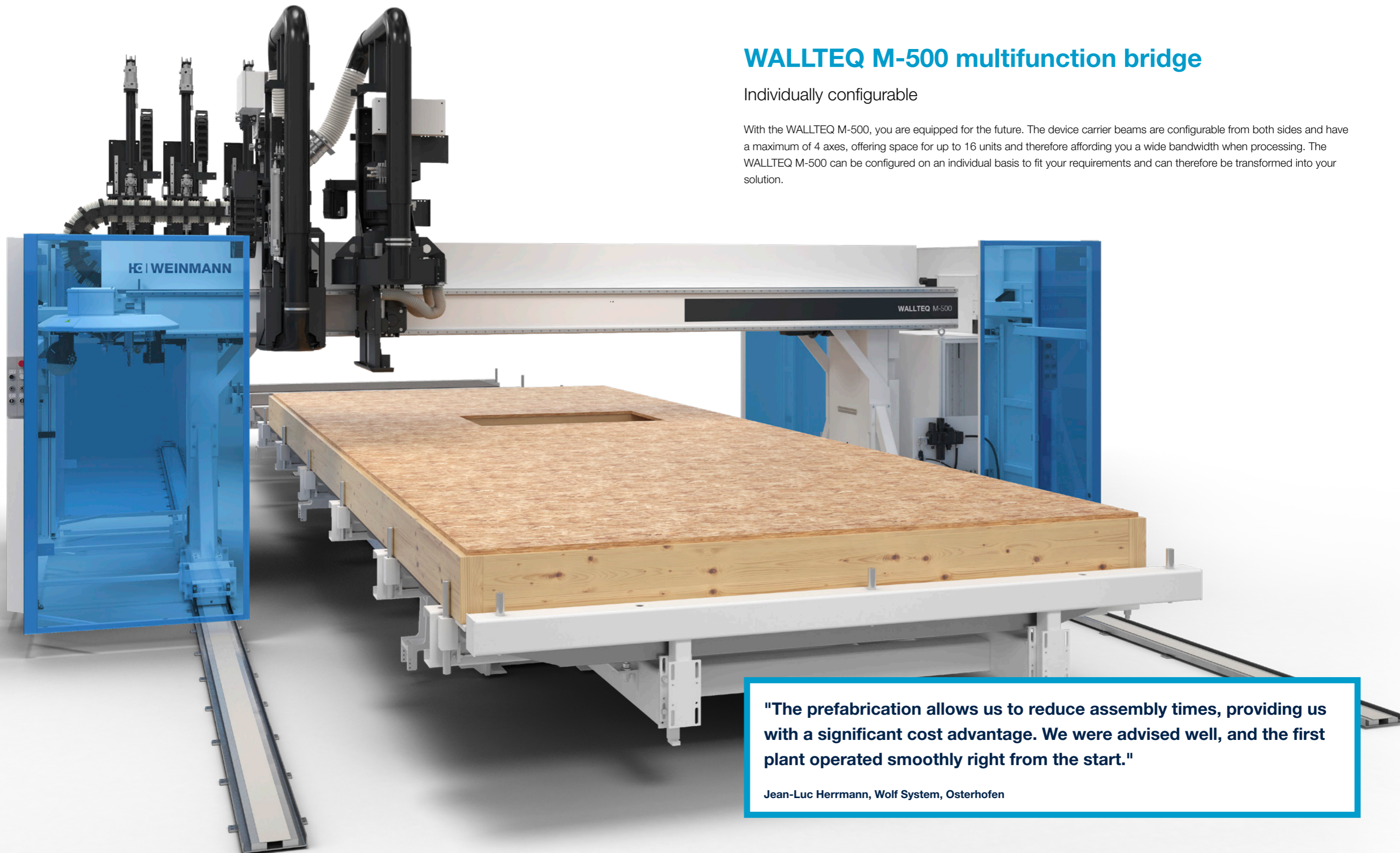

WALLTEQ M-500 multifunction bridge

Individually configurable

With the WALLTEQ M-500, you are equipped for the future. The device carrier beams are configurable from both sides and have a maximum of 4 axes, offering space for up to 16 units and therefore affording you a wide bandwidth when processing. The WALLTEQ M-500 can be configured on an individual basis to fit your requirements and can therefore be transformed into your solution.

"The prefabrication allows us to reduce assembly times, providing us with a significant cost advantage. We were advised well, and the first plant operated smoothly right from the start."

Jean-Luc Herrmann, Wolf System, Osterhofen



WALLTEQ M-500

An incredible range of processing options

Thanks to the additional processing units, you will also be well-positioned to meet future requirements. The WALLTEQ M-500 offers a large number of possibilities, ranging from sawing and trimming to drilling, marking and labeling.



Trimming



Fully automatic sawing

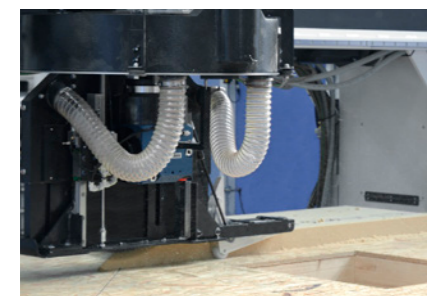

Flex 25 sawing unit



Processing gypsum plasterboard



Formatting the roof battens

- Extensive processing options:**
- 18.5-kW spindle for 12-slot tool changer
 - Sawing, trimming, drilling, marking, labeling
 - Other sawing units: Flex 5, Flex 25

- A wide range of materials:**
- Soft wood fiber
 - Gypsum plasterboard
 - SIP
 - Solid wood and CLT
 - Facade panels
 - And much more

HIGHLIGHTS:

- 12-slot tool changer
- Unlimited tool options
- High performance and flexibility

WALLTEQ M-500

More options for fastening

There are also a wide variety of expansion options for fastening. In addition to staples and nails, for example, you can also use screws. It is also possible to increase performance with parallel fastening and nail pushers.



Batten shoe

Automatic batten positioning and fastening. Longitudinal and transverse battens can be fastened with coil nailers.

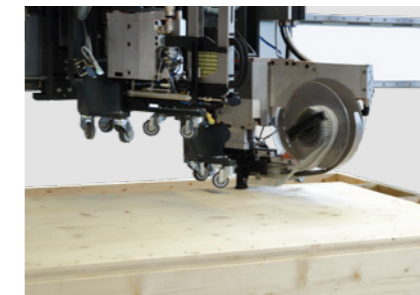

Nail pusher

Using the nail impression unit also significantly increases the quality of fastening. One common area of application is the fastening of gypsum plasterboard. Speed: 1.25 sec/nail



Parallel attachment

The sheathing is secured in parallel with two identical fastening units. Up to 40% higher performance can be achieved.

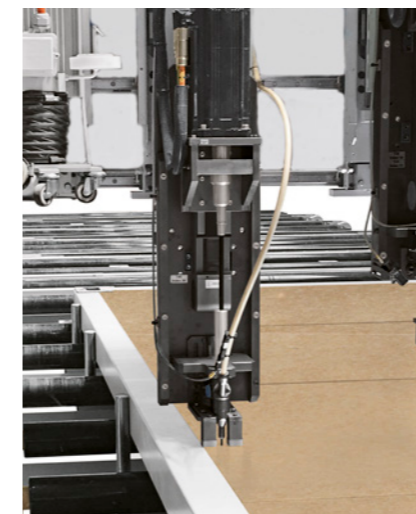

Swiveling units for nailing devices

- Swiveling unit for meeting the correct edge clearances, for example in the case of narrow studs or 2" x 4" construction method
- Horizontal swiveling to correctly attach soft wood fiber panels

Screws

Fastening with screws is especially suited to gypsum plasterboard or assembly panels. Only approx. 2.5 seconds are required per screw. Loose screws with a length of up to 250 mm can be separated automatically.

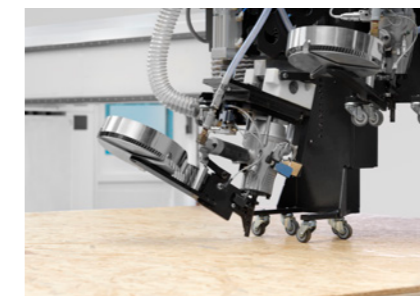

Fastening shuttering boards

The fastening units also allow you to automatically fasten boards for eaves shuttering.

HIGHLIGHTS:

- Staples, nails, screws, nail impressions
- Additional units for fastening to protect materials
- Automatic slat positioning and fastening

WALLTEQ M-500

Special areas of application

The WALLTEQ M-500 demonstrates its multifunctionality in a host of other areas. The application and attachment of the battens, pre-cutting of panels and gluing are just a few examples.



Fully automatic placement of battens

- Fully automatic fitting, positioning and fastening of the battens on the element
- Slats and shuttering boards with a size of min. 24 x 48 mm and max. 60 x 150 mm
- The capacity of the piggyback board magazine is sufficient for a complete tier (12 m) of beam shuttering or exposed shuttering
- The board magazine is filled manually or automatically

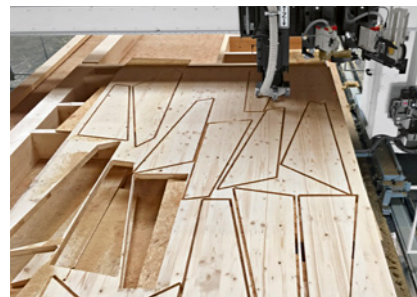

Fully automatic plate layout with nesting function

- Material savings and optimization of waste
- Manufacturing free contours without bars
- Also suitable for facade panels and other large-format panels such as CLT, sandwich or non-wood elements



Gluing

Using a multi-nozzle system means that individual components and surfaces can be glued quickly.

WALLTEQ M-300/M-500 insuFill multifunction bridge

Automated insulation

With the WALLTEQ M-300 insuFill, you can insulate your timber construction elements fully automatically. The CNC-controlled multifunction bridge positions the blow-in plate precisely above the compartment. All specifications for the insulating process, such as the position, shape and size of the compartment, are transmitted to the blow-in plate via an interface.



WALLTEQ M-300 insuFill – Pure insulating station

- Fully automatic insertion of loose insulating material into wall, roof, ceiling, gable and special elements
- Can be combined with any work tables
- Faster throughput times thanks to shorter cycle times, ideal for medium-sized companies and industrial companies
- Optional: blow-in plate that can be rotated by 90° for ceiling and roof elements



WALLTEQ M-500 insuFill – The all-rounder for insulating and processing

- Fully automatic insertion of loose insulating material into wall, gable and special elements
- Can be combined with any work tables
- High flexibility for small and medium-sized companies
- Optional: a wide range of processing and fastening options



A wide range of insulating materials

Loose insulating materials such as cellulose, wood fiber and mineral wool can be inserted.



Optimal density distribution

Automatic calculation of the filling quantity for optimum and uniform density distribution of the insulation per compartment.

HIGHLIGHTS:

- Quality assurance thanks to seamless documentation and verifiable fill quantities
- Optimal and uniform density distribution of the insulation per compartment
- Work processes become more pleasant since the volume of dust is significantly reduced
- Significant material savings, since there is no material waste
- High level of efficiency thanks to rapid and uniform insertion of the insulation

State-of-the-art technology for your production

Since it can be combined with individual table concepts and a travel path of up to 50 m, the WALLTEQ is even able to process the largest element dimensions, which means that you will also benefit from a high level of durability and availability. High safety standards are guaranteed by light barriers and motion detectors.

WALLTEQ M-300

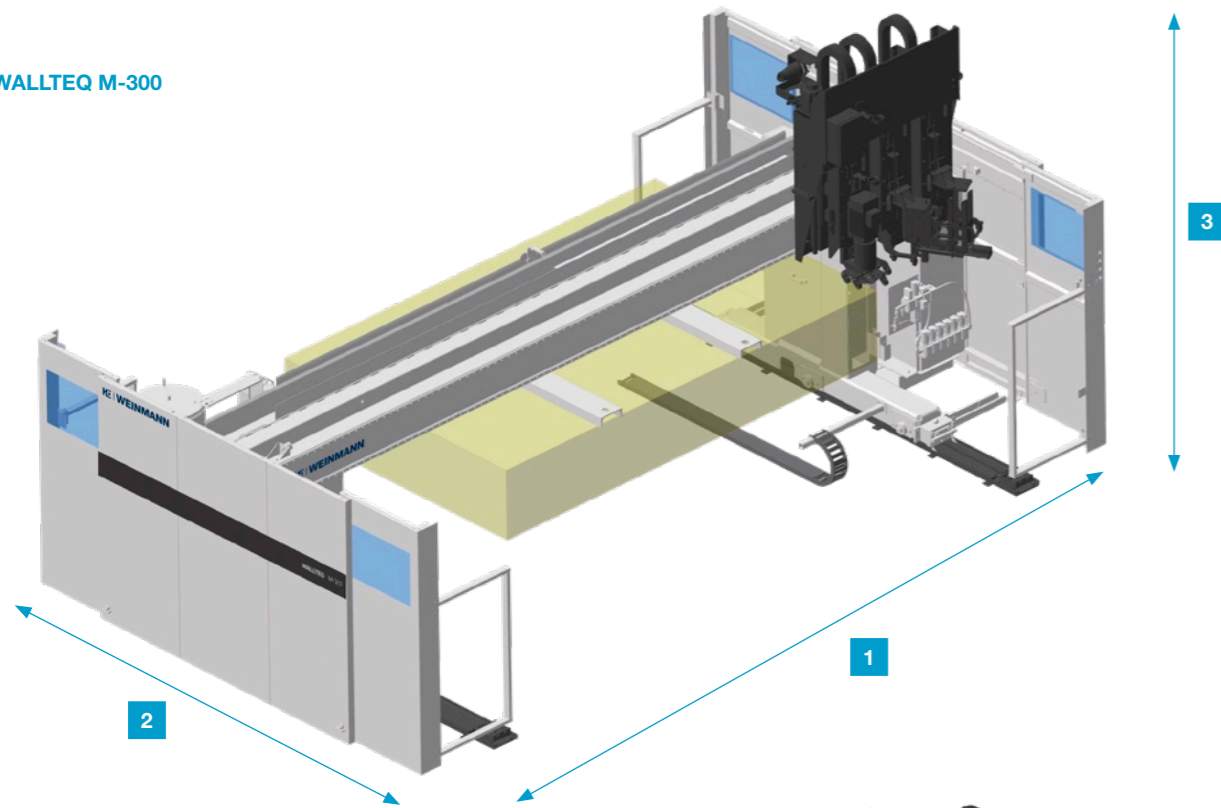

WALLTEQ M-500

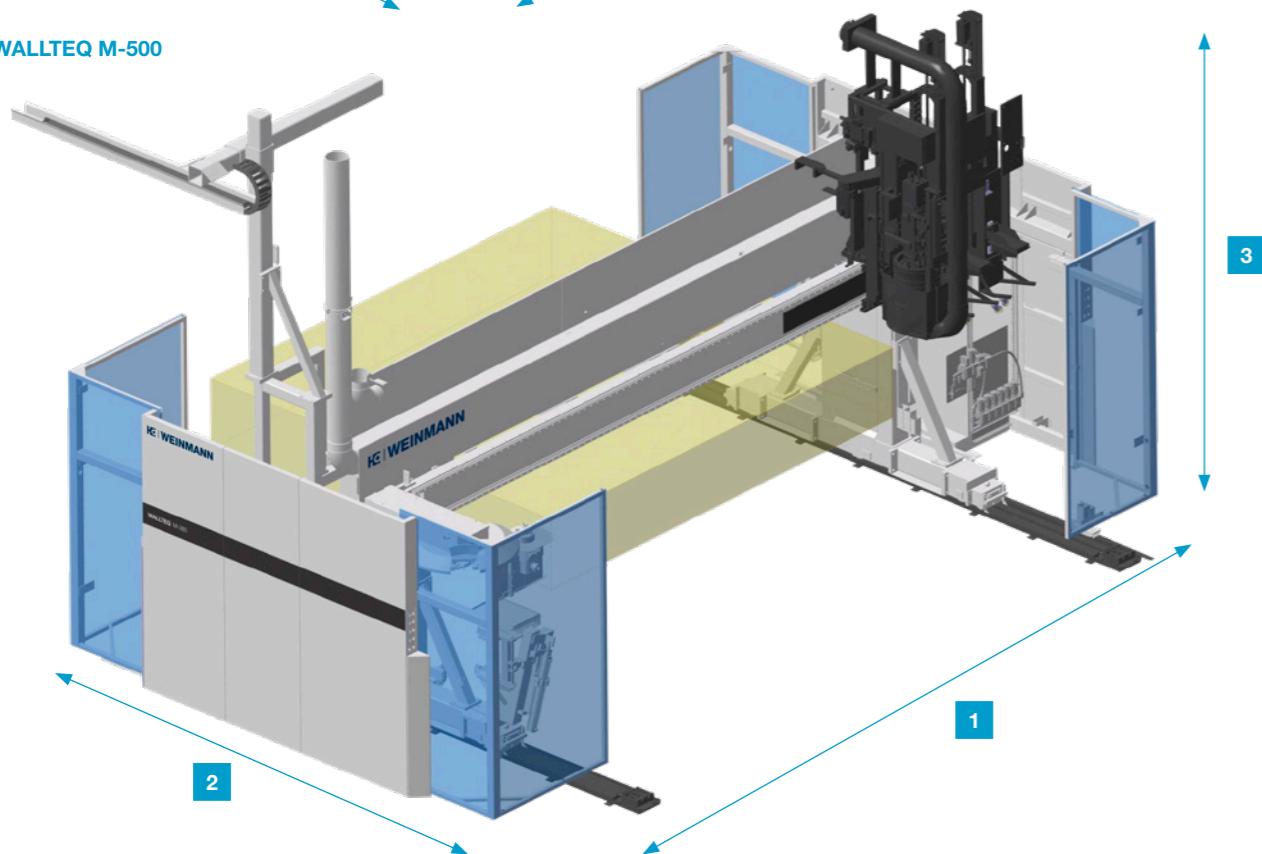

	WALLTEQ M-300	WALLTEQ M-500
1 Width (mm)	5770/6450	6400/7100/7900
2 Length (mm)	3840	4000
3 Height (mm)	3110	3700
Weight (tons)	4	5,5

Product dimensions	WALLTEQ M-300	WALLTEQ M-500
Width (mm)	3200/3810	3200/4200
Length (mm)	Customer-specific up to 50,000	
Height (mm)	500	

	WALLTEQ M-300	WALLTEQ M-500
Processing depth (mm)	Up to 80 depending on the tool	Up to 195 depending on the tool
Piggyback suction device performance (m³/h)	750	1850
Central extraction system performance [m³/h]	1100	2200
Electrical connection value (kW)	25	20-40
Compressed air connection value (NI/min)	1500	
Pneumatic pressure (bar)	8	

Configuration options

The choice is yours. The available options provide you with a wide range of possibilities to adapt your multifunction bridge according to the requirements of your production. In the table you will find an overview of the options that are possible in the respective machine types.

	WALLTEQ M-300	WALLTEQ M-500
Extraction concepts		
Piggyback	✓	✓
Central extraction system	✓	✓
Energy chain		
On the floor	✓	✓
On consoles at a height of 4–4.5 m	✓	✓
Embedded in the floor shaft		✓
Handling		
Remote control		✓
Piggyback feed adjustment		✓
Machine		
Bridge expansion	✓	✓
Travel path extension	✓	✓
Increased accuracy		✓
Increased dynamics		✓
Cooling unit	✓	✓
Heating unit	✓	✓
Units		
Additional units beam		✓
Gluing unit		✓
Blow-in plate construction/preparation		✓
Automatic board magazine		✓
Semi-automatic board magazine	✓*	✓
fastenerSwitch	✓	✓
Quick change of fastening units		✓
Pickup station		✓
Label printer		✓

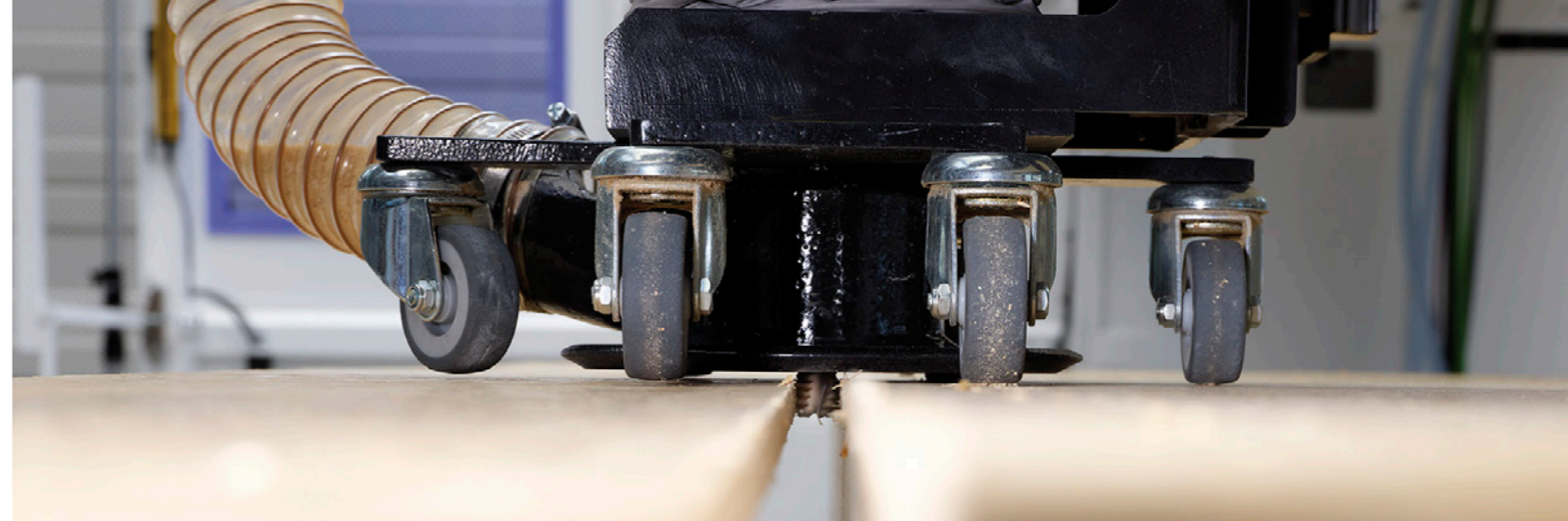

	WALLTEQ M-300	WALLTEQ M-500
Fastening units		
Second fastening unit	✓	✓
Parallel attachment		✓
Sliding shoe for soft wood fibers	✓	✓
Nail pusher		✓
Rotating unit for bracket units	✓*	✓
Swiveling nailing unit in the Y direction	✓	✓
Automatic height adjustment of the fastening units	✓*	✓
Screw unit		✓
Processing units – tool changer		
Spindle drive 13.2 kW	✓	
Spindle drive 18.5 kW		✓
Sawing up to 80 mm	✓	✓
Sawing up to 105 mm		✓
Sawing up to 135 mm (pick-up station)		✓
Drilling (tool-dependent)	✓	✓
Trimming (tool-dependent)	✓	✓
Flex 5 sawing unit up to 55 mm		✓
Flex 5 sawing unit preparation		✓
Marking ballpoint pen	✓	✓
Marking inkjet printer		✓
Labeling inkjet printer		✓
Processing units – single units		
Sawing up to 65 mm (1.5 kW)		✓
Flex25 sawing up to 195 mm (20 kW)		✓
Trimming up to 60 mm (5 kW)	✓	
Trimming up to 90 mm (13,2 kW)		✓

* with fastenerSwitch



Software for the machine

wupWorks for the machine

wupWorks is the user interface for your machine's control system. The software automatically reads in, optimizes and processes the data records generated by the CAD. Thanks to the data interface, the machine is controlled independently of the CAD. In addition, the software enables you to graphically display workpieces and to control processing. You can assign machine functions, and travel paths and the use of tools are optimized.

wupViewer for the machine

With wupViewer, you can import data from the CAD program and visualize it graphically. With the clear 3D display, you can easily check the workpieces and machine processing..

wupEditor for the machine

wupEditor is used to transfer and graphically display data from the CAD program. In addition to wupViewer, not only can you import and graphically visualize the workpieces, but also edit them. This allows you to remain flexible and create and extend components directly on the machine. You can also display, adjust or delete processes.

MMR Basic and MMR Professional

With MMR you have absolute transparency: How many parts are produced on which machine? How busy are the machines and what is the proportion of waiting or malfunction times? This information can be very useful for effective operation of your production. MMR Basic is available on every machine and shows you selected key figures. The MMR Professional extension is available as an option and allows you to graphically evaluate the machine statuses and counters in the form of diagrams directly on the machine. In addition, the operator can add any possible causes of malfunction to the machine.

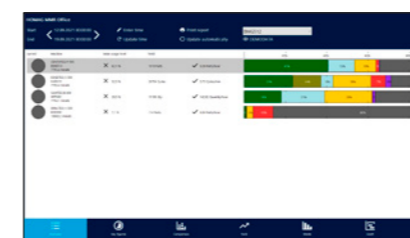
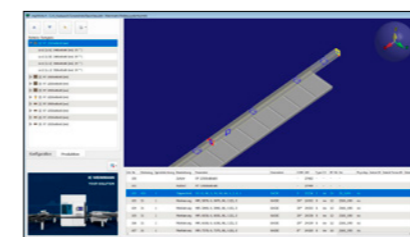
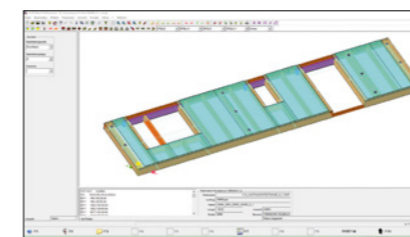
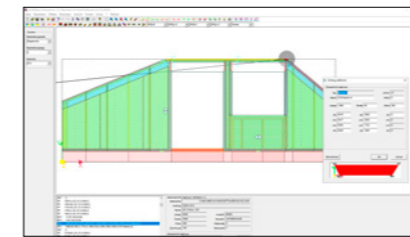
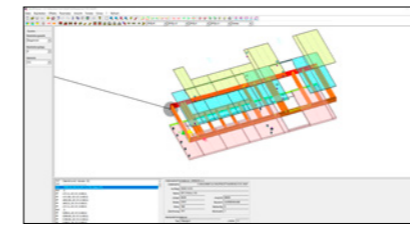

Software for the office

wupViewer Office

With wupViewer, you can import data from the CAD program and visualize it graphically. The software is used for checking workpieces and machine processing during work preparation. The software is available as a free download on our website.

wupEditor Office

wupEditor is used to transfer and graphically display data from the CAD program. As an extension to wupViewer, not only can you import and graphically visualize the workpieces, but also edit them. wupEditor for the office can be purchased as a floating license or as a single user license.

wupWorks 3 Office

With this software, you can read in and visualize WUP data records. This allows you to check whether components can be manufactured on the multifunction bridge during work preparation. wupWorks 3 can be purchased as a floating or single user license and is available for download as a trial version on our website.

wupWorks 4 Office

With wupWorks 4, you can read in and visualize WUP or BTL data records. During work preparation, you can thereby check whether components can be manufactured on your carpentry machine and optimize unprocessed parts for orders or further production. The software can be purchased as a floating license or as a single user license and is available for download as a trial version on our website.

MMR Office

MMR Office copies the data from several machines to a separate database in the office. This has the advantage that the data can be viewed centrally there. The software enables you to make the machine data available for further evaluations and to connect machines from other manufacturers.



INFO

WEINMANN

Downloads and trial versions

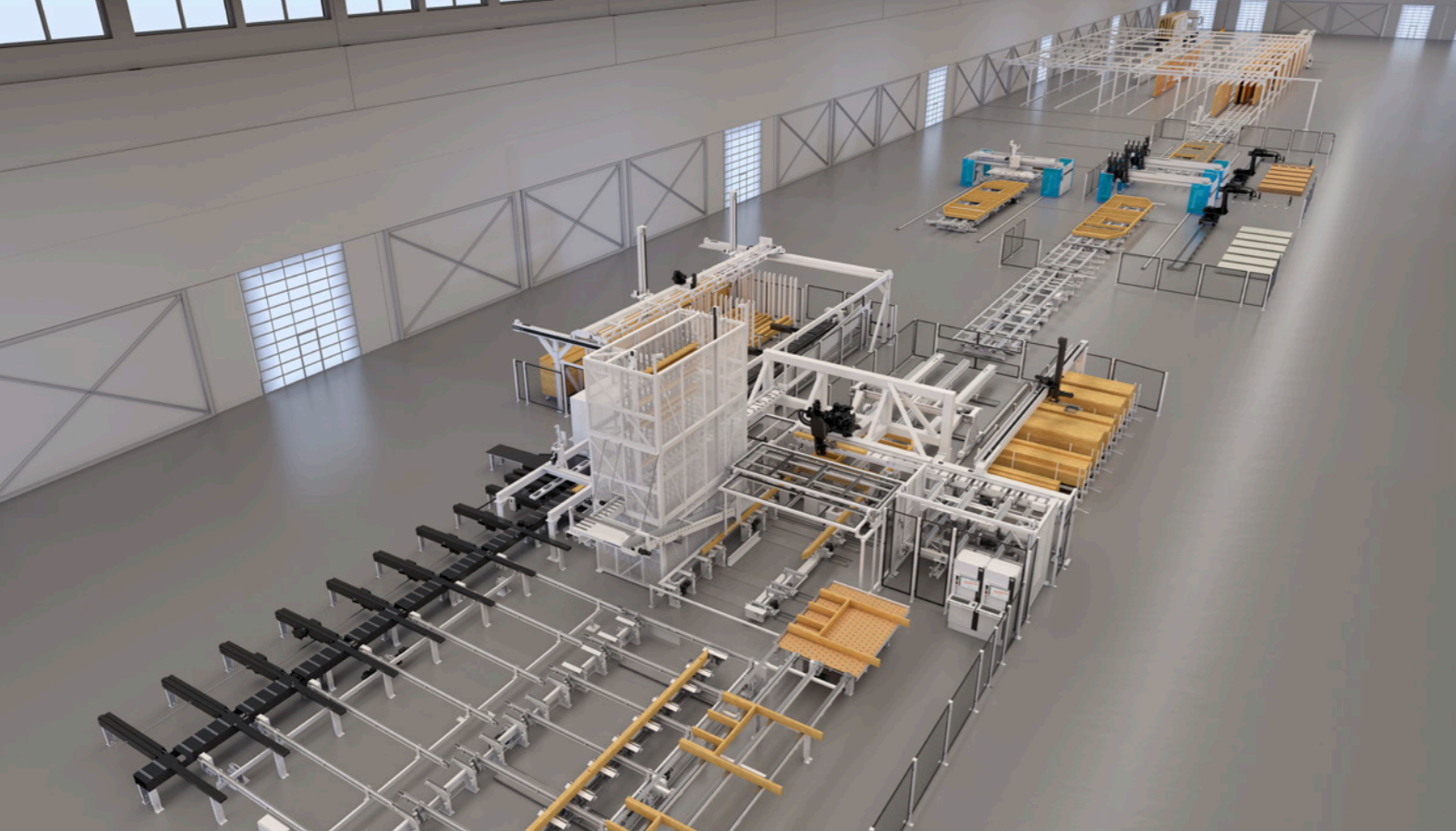

Apps and digital assistants.

Quick and easy support in your machine environment.

Some people still use pen and paper to create their cutting patterns. But they look at their smartphone if they want to know what the weather is like – instead of looking out of the window. We asked ourselves: why not combine the best of both? Our apps and digital solutions make your everyday work easier: machines, material, tools, cutting patterns, components – you always have everything in your pocket or on your desk.



More information at digital.homag.com



Software for controlling production lines

MES control systems are used to plan, optimize and control complex production processes. With automated process and route planning, they create the basis for maintaining cycle times at all production stations and ensure optimum production sequences. In this way, you can increase production efficiency and the cost-effectiveness of your company. Thanks to an appropriate software interface, machines from WEINMANN can be integrated into various MES control systems.

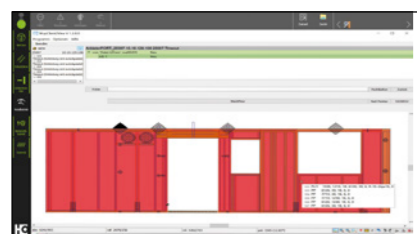

wupClient:

The interface between the machine and the MES control system

wupClient enables communication between the production line control unit and the machine. The software is installed on the machine and requests the necessary data for production fully automatically. In combination with the production line control unit, wupClient controls the production flow centrally. The machines receive all required information at the right time and the elements are produced in the desired order. During production, the operator only has to give the start signal and supervise the production process.

RoboticsClient:

The interface between the robot, multifunction bridge and MES control system

The RoboticsClient is responsible for the collaboration between a panel positioning robot and a multifunction bridge and its connection to a production control system. By automatically dividing the data record into safety zones, the bridge can begin to process the component position before the panels of a layer have been completely deposited by the robot. This allows both machines to work simultaneously and thereby save time. The safety zones can also be displayed in RoboticsClient. The client can also communicate with an MES system, which means that no user interaction with RoboticsClient is necessary for successful production. Evaluation of the machine statuses and counters in the form of diagrams directly on the machine. In addition, the operator can add any possible causes of malfunction to the machine.

WE HAVE DEVELOPED POWERFUL AND SMART SOLUTIONS FOR YOU:

- ✓ Always low investment
- ✓ Always up to date (no updates necessary)
- ✓ Always easy to use (no complex software)
- ✓ Always helpful

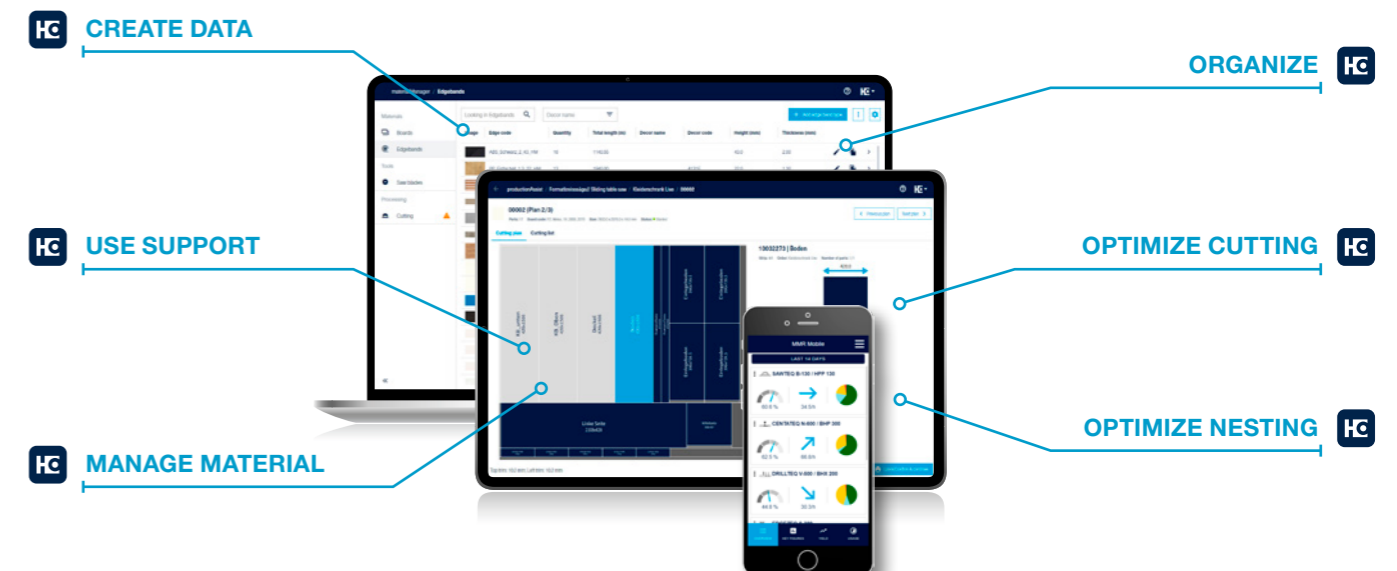

LIFE CYCLE SERVICES

Improved performance, more efficient processes, faster help, assurance of availability and smarter working

TEAM & COVERAGE

Largest global service network in the industry with over 1,350 personnel.

INSTALLATION & COMMISSIONING

For a smooth start, we only let proven experts manage your setup.

OPERATION & CONTROL

After teaching your personnel the intuitive control system, our clever apps help to make the operator's life much easier.

MAINTENANCE & SERVICING

To keep things running, we're happy to take a preventative approach. You decide how often and how intensively you want the support to be. As we all know, prevention is better than the cure.

eSHOP & ONLINE ADVANTAGE

A few clicks and it's fixed. Receive exclusive advantages by ordering spare parts online, depending on market availability. shop.homag.com

HOTLINE & READINESS

When there's an emergency, we're here. Direct by phone, digitally via app or video, or with on-site support. We are close to you with over 90 regional service organizations worldwide. With more than 35,000 spare parts immediately available, we can deliver 85% of your orders fast.

TRAINING & EDUCATION

With classroom, live online or eLearning training, we offer flexible options to help you get knowledge. We conduct over 4,000 customer training courses every year, and we even have our own training centers in 19 countries

MODERNIZATION & IMPROVEMENT

Our modernization program is tailored to your machines and processes. We can evaluate your data and situation and advise you on the next step.

ANALYSIS & SUSTAINABILITY

On request, we analyze all your processes with proven tools and procedures (LeanSixSigma). We have a large, certified team of experts for this purpose.

FINANCING & CONSULTING

We offer you tailor-made financing concepts worldwide. With more than 60 years of experience and a close partner network of prominent banks and insurance companies to help us to find the right solution for you, we're always transparent and reliable in processing.

Fast support:
94% resolution rate
via our hotline

Close to you:
1,350 service experts worldwide

We get things moving:
Over 1,000 worldwide spare parts
shipments each day

No one else has that:
Electronic documentation on over
150,000 machines, available in 28
languages



WEINMANN Holzbausystemtechnik GmbH

info@weinmann-partner.de
www.homag.com/weinmann

YOUR SOLUTION